



# **Neonatal Incubator Embedded Temperature Observation and Monitoring Using GSM**

**Zaid H. Al-Sawaff<sup>1,2\*</sup>, Yahya Zakariya Yahya<sup>3</sup> and Fatma Kandemirli<sup>4</sup>**

<sup>1</sup>*Biomedical Engineering Department, Technical Engineering College, Northern Technical University, Mosul, Iraq.*

<sup>2</sup>*Department of Materials Science and Engineering, Faculty of Engineering and Architecture, Kastamonu University, Kastamonu, Turkey.*

<sup>3</sup>*Auckland Bioengineering institute, The University of Auckland, Auckland, New Zealand.*

<sup>4</sup>*Biomedical Engineering Department, Faculty of Engineering and Architecture, Kastamonu University, Kastamonu, Turkey.*

## **Authors' contributions**

*This work was carried out in collaboration between all authors. Author ZAH designed the study, performed the statistical analysis, wrote the protocol, and wrote the first draft of the manuscript. Authors YZY and FK managed the analyses of the study. Author FK managed the literature searches. All authors read and approved the final manuscript.*

## **Article Information**

DOI: 10.9734/JERR/2019/v4i116895

### Editor(s):

(1) Dr. Heba Abdallah Mohamed Abdallah, Associate Professor, Department of Chemical Engineering, Engineering Research Division, National Research Centre, Egypt.

### Reviewers:

(1) Aliyu Bhar Kisabo, Nigeria.

(2) Anand Nayyar, Graduate School, Duy Tan University, Da Nang, Vietnam.

(3) Vikram Puri, Duy Tan University, Vietnam.

(4) Raheel Muzzammel, University of Lahore, Pakistan.

Complete Peer review History: <http://www.sdiarticle3.com/review-history/47643>

**Received 10 December 2018**

**Accepted 26 February 2019**

**Published 12 March 2019**

**Original Research Article**

## **ABSTRACT**

In order to reduce the risks of death rates, neglecting by the observers, and sometimes the little number of the medical staff in hospital, A monitoring system based microcontroller in neonatal incubator was developed in this article. An interfacing process is made between the infant, infant incubator, and the computer, by taking the temperature readings and send the results to doctor's or the person who in- charge's phone through Short Messages Service, and to a personal computer PC, with sound alarm on the incubator, every given period of time; A temperature sensor is interfaced with a configured single inline module SIM of phone, the temperature reading that obtained from interfacing method is combined with the readings of the incubator sensor, then the

\*Corresponding author: Email: [zaidh.sawaff@gmail.com](mailto:zaidh.sawaff@gmail.com);

final result will be taken from the microcontroller because it will be more accurate than the incubator's thermometer.  
This system was designed only to check and give an alarm if there was any unaccepted change in temperature due to the normal temperature ranges.

*Keywords: SIM; SMS; thermistor; temperature-sensor; Arduino.*

## 1. INTRODUCTION

Infants who born before 9 months of the gestation period are known as the premature babies. Studies shows that in every month of birth around 4 million infants die in all over the world, 25% of the deaths are cause due to complications of prematurity, most often heat and water [1]. Vital organs, and enzymes of premature babies grows to the very less extent, and thus it requires special attention to deal with external physical conditions like temperature, humidity, light etc.

Infants have many several disadvantages in regarding to thermal regulation. All infants have a relatively large surface area, poor thermal insulation, and a small amount of mass to act as a heatsink. The new-born has little ability to deal with heat by changing posture and no ability to adjust their own clothing in a response to thermal change, So these parameters are most important to control life - saving of infants.

In developing countries, because of the economy situation is very low; the cost of medical devices should be kept low. Thus there is a need to develop a low cost incubator which provides the facilities required for the infants.

This article present a system which includes system structure, hardware circuits, and software program for the neonatal incubator.

Joshi et al. in [2] described the development of a Wireless Monitoring System for Neonatal Intensive Care Unit (NICU); which is an isolated room for a pre- mature/weak newborn babies, the system provides the environmental condition similar to Mother's Womb. because of the lack of attention to thermoregulation, death rates are still large in the neonatal population.

Salim et al. in [3], described the design and implementation of a fully digital and programmable temperature system for the Baby Incubator. The transmitter circuits was also designed and implemented for all the

variables of the incubator that are used as control signals like the air temperature sensor (thermistor), baby skin temperature sensor (probe).

Bouwstra et al in. [4], designed a Smart Jacket for neonatal monitoring system with wearable sensor. That smart Jacket aims for providing reliable health monitoring as well as a comfortable clinical environment for neonatal care and parent-child interaction.

In this paper the author explore a new solution for skin-contact challenges that textile electrodes pose. The jacket is expandable with new wearable technologies and has aesthetics that appeal to parents and medical staff.

Kumar et al. in [5] has done the study on designing an infant incubator for improved usability. That study helped to achieve the customer needs, which were later converted into technical voice for the development of quality functional deployment (QFD), based on which final design specification (PDS) was listed, were there was five different concepts were generated. The final concept is selected based on Pugh's method of concept selection. From that study, the finalized concept has superior usability features compared to that in the present market.

These data obtained can reduce the risk of many sudden cases like (hypothermia, hyperthermia, Heat syndromes, cramps, stroke etc.).In neonates hyperthermia rarely does occur but for an external source like

- Overzealous re-warming
- Poorly serviced equipment
- Misuse of warming lamps
- Incubator too close to a sunny window
- Temperature probe not in good contact with)

In developing countries, the use of remote health monitoring system application enables doctors from monitoring patient's temperature practically based on web and GMS, where death rates were increased most painfully due to

inadequate prompt attention [3]. The task was developed by making the function of collection of patient's temperature and give it to doctors or the responsible staff by the use of web or GSM, which they remotely monitor their patients, and removing the barrier of distance [4].

The application of remote temperature monitoring (RTM) has wide field in the life. GSM network provide a tool to take and view temperature readings anytime and anywhere by receiving these readings by cell phones or other mobile devices making distance a non- issue [5].

## 2. BACKGROUND OF NEONATAL INCUBATOR

The incubator process is used to produce healthful micro-environment in order to reduce new born heat loss by controlling temperature inside incubator [11]. Temperature is one of the most important factors that need to be maintained with a minimum variation. But only temperature control is not sufficient to provide comfortable environment. Also, the relative humidity control is very important to reduce the new born heat loss. In the current neonatal incubator systems, temperature is the only variable detected, which has been monitored at the incubator's site only without any further observation [4]. A neonatal incubator, which is represented in Fig. 1, consists of a rigid box built in fiber and steel, where an infant may be kept in a controlled environment for medical care. The device includes an AC-powered heater, an electrical motor fan to circulate the warmed air, a water container to add humidity, a mechanical filter through which the oxygen flows and an access port for nursing care. The electric motor allows the air to circulate into the neonatal incubator through an air inlet at the bottom of the equipment. It influences the temperature and humidity levels inside the incubator dome, as well as the oxygen level. The air is renewed by a set composed of an electrical exhaust fan and an air inlet [5].

## 3. DESIGN AND IMPLEMENTATION APPROACH

The layout and also the execution approach defines the procedure's ingredients of the mooted system along with the interactions between these ingredients. The circuit diagram representation of the developed model is shown in Fig. 2.



Fig. 1. Incubator system

The scope of normal values is set before the system starts taking any readings. All the ingredients required to take the readings of the temperature are initialized [11]. The monitoring system now starts its work in an unending loop until it is manually halted. The mooted system will read the temperature in analogue data, then the analogue to digital converter (ADC) will convert these data to digital format. The converted format will be compared to the present values. If the read value is within the present scope the value will be transmitted to the local server where it will be displayed in tabular format and display results. If the read value is outside the scope, a warning is sent to the doctor and the nurses, with sound alarm in the incubator.

The temperature reading taken from the sensor attached to the wristwatch placed on the hand of the infant was fed to an ADC port of the microcontroller, in order to convert analog readings from the sensor to digital [12]. Also, upon a given command, the microcontroller will read the temperature sample. It was then being converted and stored in the microcontroller memory as two 8-bit unsigned integers (0-255).

After completion of signals acquisition and comparison with preset values, the microcontroller then constructs the SMS messages as well as emails and packs the data samples in these messages to the desired length, it then communicates with the mobile phone using at-commands on its serial port to send the message(s) [13]. The device records temperature data continuously. When a temperature reading exceeds the present values, an alarm is triggered, and an email and a SMS

message was sent to the in-charge doctor, then, the measured values are sent to the local web server and displayed on the website of the hospital in a tabular format; this assists the doctor(s) in taking correct decisions based on the accurate data; as shown in the flowchart bellow (Fig. 4).

The LM35 series, are precision integrated-circuit temperature devices with an output voltage linearly proportional to the Centigrade temperature.

The LM35 device has an advantage over linear temperature sensors calibrated in Kelvin, as the user is not required to subtract a large constant voltage from the output to obtain convenient Centigrade scaling. The LM35 device does not require any external calibration or trimming to provide typical accuracies of  $\pm\frac{1}{4}^{\circ}\text{C}$  at room temperature and  $\pm\frac{3}{4}^{\circ}\text{C}$ , over a full  $-55^{\circ}\text{C}$  to  $150^{\circ}\text{C}$  temperature range. Lower cost is

assured by trimming and calibration at the water level.

The low-output impedance, linear output, and precise inherent calibration of the LM35 device makes interfacing to readout or control circuitry especially easy. The device is used with single power supplies, or with plus and minus supplies. As the LM35 device draws only  $60\ \mu\text{A}$  from the supply, it has very low self-heating of less than  $0.1^{\circ}\text{C}$  in still air. The LM35 device is rated to operate over a  $-55^{\circ}\text{C}$  to  $150^{\circ}\text{C}$  temperature range, while the LM35C device is rated for a  $-40^{\circ}\text{C}$  to  $110^{\circ}\text{C}$  range ( $-10^{\circ}$  with improved accuracy). The LM35-series devices are available packaged in hermetic TO transistor packages, while the LM35C, LM35CA, and LM35D devices are available in the plastic TO-92 transistor package. The LM35D device is available in an 8-lead surface-mount small-outline package and a plastic TO-220 package [13].

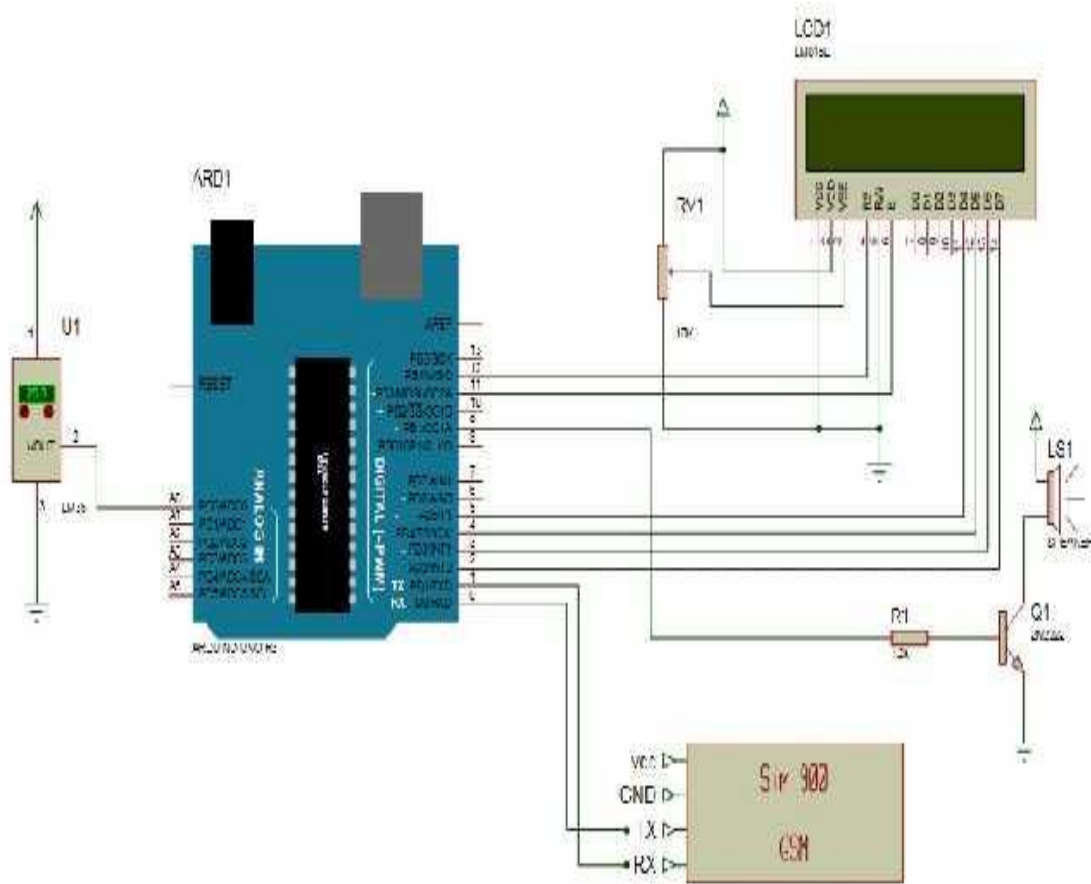

Fig. 2. Circuit diagram of developed system

**Device Information<sup>(1)</sup>**

PART NUMBER	PACKAGE	BODY SIZE (NOM)
LM35	TO-CAN (3)	4.699 mm × 4.699 mm
	TO 92 (3)	4.30 mm × 4.30 mm
	SOIC (8)	4.90 mm × 3.81 mm
	TO-220 (3)	14.086 mm × 10.16 mm

(1) For all available packages, see the orderable addendum at the end of the datasheet.

**Full-Range Centigrade Temperature Sensor**

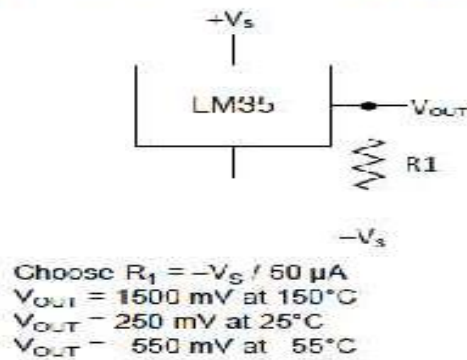

The SMS message can be programmed as the doctor's request, in this system the message would be sent is {emergency in incubator no. ( )}.

As a future scope, the designed system could have some precaution solution to reduce the unusual or unaccepted change in temperature by adding extra cooling fans to the incubator.

**4. ARDUINO BOARD**

Arduino is an open source computer hardware and software company, project, and user community that designs and manufactures single-board microcontrollers and microcontroller

kits for building digital devices and interactive objects that can sense and control objects in the physical and digital world. Arduino board designs use a variety of microprocessors and controllers [10,12]. The boards are equipped with sets of digital and analog input/output (I/O) pins that may be interfaced to various expansion boards or Breadboards (shields) and other circuits. The boards feature serial communications interfaces, including Universal Serial Bus (USB) on some models, which are also used for loading programs from personal computers [6]. Fig. 5 shows the Arduino board.



**Fig. 3. Parts of the system**



## PROGRAMMING

```

#include <LiquidCrystal.h>
LiquidCrystal lcd(12, 11, 5, 4, 3, 2);
float t;
int x;
int y;
int s;
int m;
int b;
int f=3;
void setup() {
  Serial.begin(9600);
  lcd.begin(16, 2);
  pinMode(9,OUTPUT);
}
void loop() {
  x=millis();
  if(x-y>=1000){s++;y=x;}
  if(s==60){m++;s=0;}
  t=analogRead(A0);
  t=(t*5.0)/1023.0;

  t=t*100;
  lcd.setCursor(0,0);
  lcd.print("Zaid Al-sawaf ");
  lcd.setCursor(0,1);
  lcd.print(" ");
  if(m==3){
    if(b==1){send_sms();}
  }
  if(m==f){
    for(int j=0;j<60;j++)
    {
      delay(1000);
      t=analogRead(A0);
      t=(t*5.0)/1023.0;
      t=t*100;
      if(t<29.0){lcd.setCursor(0,1);lcd.print("ALARM.....");analogWrite(9,200);f=1;b=1;}
      else if(t>36.0){lcd.setCursor(0,1);lcd.print("ALARM.....");analogWrite(9,200);f=1;b=1;}
      else{lcd.setCursor(0,1);lcd.print("Normal Condition");analogWrite(9,0);f=3;b=0;}
      lcd.setCursor(0,0);
      lcd.print("Temp=");
      lcd.print(t);
      lcd.print(" ");
    }
  }
}
}

```

## 5. GSM

A GSM (Global System for Mobile Communication, originally from Group Special Mobile) modem is a wireless modem that works with a GSM wireless network. A wireless modem behaves like a dial-up modem, except the main difference between them is that a dial-up-modem sends and receives data through a fixed telephone line, while a wireless modem sends and receives data through radio waves [7]. The GSM Association estimate that 80% of the global mobile market uses the standard A GSM modem is a wireless modem that works with a GSM wireless network. Global Positioning System is one of the widely

used mobile standards. As the name specifies, it enables the mobile users to interact all over the world at any time [15]. It is a hardware component that allows the capability to send and receive SMS to and from the system. Communication with the system is carried out via RS232 serial port. Cell phone can be attached at the place of GSM hardware but it limits the hardware functionality such as sending or receiving of SMS [8]. The dominant mobile phone network in the world today is GSM. It is a digital mobile communication network, which developed, rapidly in recent years. This network has coverage in most urban areas and offer support for the SMS [9].

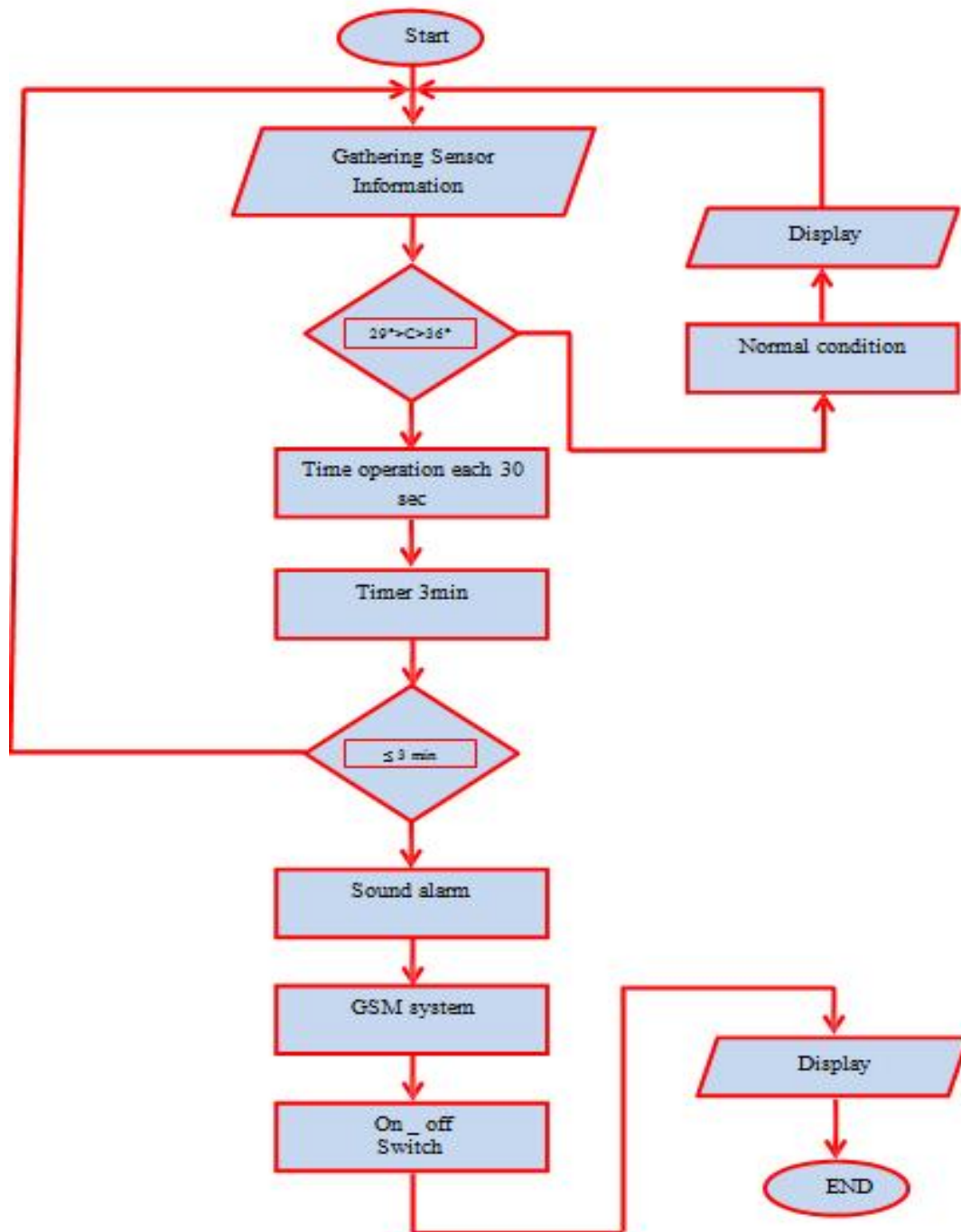

Fig. 4. Flowchart representation of the developed model

## 6. SYSTEM TESTING AND RESULTS

The results obtained were tested and confirmed under normal temperature and dustless environment and agreed with the expected results which were displayed on the Liquid

Crystal Display (LCD). The results obtained were compared and tabulated as shown in Table 1. From the result, it was seen that there was little or no variation in the patient's readings from the clinical thermometer and the monitoring unit.



Fig. 5. Arduino board

Table 1. Readings results comparison between the incubator thermos sensor and the microcontroller sensor

Subject	Readings from Clinical Thermometer (C°)	Readings from infant body using microcontroller sensor (C°)
Patient A	30	30.5
Patient B	33.6	34.1
Patient C	36.5	37.5
Patient D	30.2	31.7
Patient E	37.1	37.9

## 7. CONCLUSIONS AND FUTURE SCOPE

From the results which was obtained practically from the patient's, the accuracy of the designed system was acceptable and the efficiency of the system was very high.

The designed system is very easy to use and manufacture, and the coast of manufacturing is rather reasonable, in the other hand the size of the designed system is small and can be reduced to minimum size depending on the size of microcontroller used.

We have presented remote temperature monitoring system using microcontroller to ease the work of doctors in hospitals suffering from less number of staff, and in remote areas. The designed system was capable of helping the medical staff to make the right decision at the right time. The system is also appropriate for the monitoring of day-to-day activities in places like server rooms, hospital rooms, warehouses etc...

As a future scope, temperature controlling can be established by adding fan cooling system with the microcontroller, also different types of

sensors can be added to monitor and control other variables like: Humidity, oxygen levels, and Atmospheric pressure values, which are very easy and suitable for the microcontroller used in this system due to the presence of suitable sensors with less error.

## COMPETING INTERESTS

Authors have declared that no competing interests exist.

## REFERENCES

1. Binod P, Papamichael E, Varjani S. International Conference on Innovative Computing and Communications. 2019;55. Springer Singapore.
2. Elsheikh N, Mohammed B. Design and Development of Microcontroller Based Temperature and Humidity Controller for Infant Incubator OK, (July); 2011.
3. Gridling G. Other Microcontrollers. Introduction to Microcontrollers. 2007;379–414.
4. Information D. LM35 LM35 Precision Centigrade Temperature Sensors; 1999.



- Available: [www.ti.com](http://www.ti.com).
5. Jimmoh OH, Adedayo S, Enemakwu OS, Ajibola IN. Microcontroller-based remote temperature monitoring system. IOSR Journal of Computer Engineering, 2016; 18(04):68–72.
  6. Louis L. W Orking P Rinciple of a Rduino and U Sing I T. 2016;1(2):21–29.
  7. Mathew, Ashish Gupta HBDL. Controlling of temperature and humidity for an infant incubator using microcontroller. International Journal of Advanced Research in Electrical, Electronics and Instrumentation Engineering. 2015;04(06): 4975–4982.
  8. Murugan T, Periasamy A, Muruganand S. Embedded based industrial temperature monitoring systems using GSM. International Journal of Computer Applications. 2012;58(19):6–11.
  9. Nayyar A, Puri V. A review of Arduino board's, Lilypad's & Arduino shields. In 2016 3rd International Conference on Computing for Sustainable Global Development (INDIACom) 2016;1485-1492.
  10. Nayyar A. An Encyclopedia Coverage of Compiler's, Programmer's & Simulator's for 8051, PIC, AVR, ARM, Arduino Embedded Technologies. International Journal of Reconfigurable and Embedded Systems. 2016;5(1).
  11. Ozdemirci E, Özarslan Yatak M, Duran F, Canal MR. Reliability assessments of infant incubator and the analyzer. Gazi University Journal of Science. 2014;27(4): 1169–1175.
  12. Puri V, Nayyar A, Le DN. Handbook of Arduinio: Technical and Practice. Scholars Press; 2017.
  13. Suruthi M, Suma S. Microcontroller based baby incubator using sensors. International Journal of Innovative Research in Science, Engineering and Technology. 2015;4(12): 12037–12044.
  14. Technologies AE, Nayyar A, Puri V. An Encyclopedia Coverage of Compiler's, Programmer's & Simulator's for An Encyclopedia Coverage of Compiler's, Programmer's & Simulator's for 8051, PIC, AVR, ARM, Arduino Embedded Technologies, (March); 2016.
  15. V, S. A. T. C. I. M. A. T. C. AT Commands Set. History; 2007.

© 2019 Al-Sawaff et al.; This is an Open Access article distributed under the terms of the Creative Commons Attribution License (<http://creativecommons.org/licenses/by/4.0>), which permits unrestricted use, distribution, and reproduction in any medium, provided the original work is properly cited.

*Peer-review history:*  
*The peer review history for this paper can be accessed here:*  
<http://www.sdiarticle3.com/review-history/47643>